

THE SURVEY AND ANALYSIS OF THE SPATIAL CHILLING EFFECTS EXERTED BY SPRING HOUSES IN IRAN'S WARM AND DRY CLIMATES

Najme Zangeneh

Department of Architecture, Yasooj Branch, Islamic Azad University, Yasooj, IRAN

ABSTRACT

One of the challenges of the today's residential architecture is the optimized use of the renewable energies. In line with this and to achieve appropriate designing patterns the survey of the traditional architecture which is designed consistent with the climate can be helpful to the designers in reaching to this objective. Since, a great part of Iran is located in the dry and warm climate one of the most important climatic accomplishments obtained by the Iranian traditional architecture is the use of some elements for the purpose of exerting a chilling effect on the temperature welfare and comfort. Among such climatic elements are the pleasant and favorable spaces called springhouses. The survey of the way such spaces work and the effect they have on the comfort of the residents determines the way these spaces are taken into practical use for the purpose of creating a chilling effect in the today's designs. In the present study we have made use of interpretive-historical methodology and the analyzed sample in the current study is the springhouse situated in Shiraz's Foroogh Al-Malek House. And the data has been collected based on a documentary method accompanied with the field studies and observations. And the researcher also measured the temperature and humidity for two consecutive days in various points in the springhouse in three different occasions of morning, noon and evening and finally the researcher came to this conclusion that the existence of a springhouse assists in cooling the space. The current study is seeking to figure out that how helpful to the temperature comfort of the residents can be the establishment of a springhouse in the warm and dry climates and that can finally result in the emerging-saving effect in the warm and dry climates.

Published on: 12th- Aug-2016

KEY WORDS

springhouse, spatial cooling, energy optimization

*Corresponding author: Email: najme.zangeneh2@yahoo.com Tel.: +98 9388151547

INTRODUCTION

In ancient Iran the architecture moves towards water and it settles down in the water bodies periphery, but in the Islamic era the water finds an applied function in architecture and the architects consciously attempt to dominate over the nature and give it order. In fact, in this era the water is manifested inside a geometrical containment in the majority of the buildings and it can be stated that the architecture centrality and unity has been shaped into the water. In such a manner that the water has appeared in the center of the summerhouses, gardens and mosques and so on and in the warm and dry regions the scarce and life-bestowing water causes the formation of the water-reserves, caravansaries, shoals, frigs and springhouses and it demonstrates itself in other forms. Due to the creation of beauty, comfort and an environment replete with joy and pleasure causes the human being to gather around and accumulate in such regions with water. The physical role played by water in the architecture and the effect of the water streams on the buildings and its special effects and the psychological and mental influences cannot be simply ignored. Besides this idea, another use cases enumerated for water in traditional architecture in adapting the architecture with the warm and dry climates has been for the purpose of adjusting the air inside the houses and the traditional architects have made an intelligent use of water and its features in engineering the spaces. On the other side, nowadays, the designers forgetting to make use of the past architecture elements and concepts and by taking advantage of the modern technology and suffering from extravagant costs and creation of disturbing noises have tried to make the environmental conditions more appropriate and getting it to reach to a comfortable level, while it is clear that should for any reason such devices endure malfunctions the life in such buildings become so extensively difficult. Therefore, in order to reduce the inefficient use of the fossil energies and more polluting of the cities, elimination of the green and natural areas and to reduce the physical and psychological harms in relation to the application of too much of the technology it is better to spend the best of the efforts in reusing the climatic factors and establishing the disrupted relationship between the human and the nature. Iranian traditional architecture has

provided and invented logical methods and reasonable and convenient solutions for presenting the human comfort conditions and getting reconnected to the nature. In fact, it can be stated that such climatic methods in the traditional architecture can be considered as an alternative to the mechanical equipments for cooling the environment and now in this crisis that the nonrenewable energies are declining and dying out and according to the vastness of the dry and warm climatic conditions scattered in a substantial part of the Country of Iran we can save energy consumption besides and plus making use of the mechanical equipments to a great extent. And one such method in saving the energy is the application of the springhouses which is a healthy and fruitful synergy between the human beings and the nature and through getting the water present in the environments of the houses we can provide the grounding for the natural cooling of the space. In the current article we deal with the survey of the springhouses functions and the change they cause in the warm and dry climates temperature.

Water in Iranian architecture

Aside from the life-donating role played by water in the life of the human beings, it can be of a great importance as a sacred element. The manifestation of water in Iranian architecture can be traced back into two periods before Islam and the post- Islam era.

Water in pre-Islam architecture

Water is one of the most sacred natural elements for the ancient Iranians. Based on the ancient Iranian mythical beliefs, water has been created in the second period of the sextuple period and the “proper season” for its creation has been said to be in the middle of Tir (June). Based on such beliefs, the water has been created after the sky and before the creation of the other creatures. Ancient Iranians considered water as one of the sacred Lords and it was sanctified and revered. The water is a symbol of purity, fertility, daily food and aliment, luminosity, well-being and benediction, science and knowledge, healthiness, clear and prosperous future and so forth In pre-Islam era the role of water was more of an abstract role, the praying establishments (Anahita temple and fire-temples) were built near water and with paying so much respect to the water. The water and the fire were peacefully made in one’s another adjacency and celebrated their unification, for example Azar Gashsb fire-temple and Kavyan fire-temple (Firooz Abad), water and fire are contradictory metaphors which are being regarded as the constituting elements of the entire universe along with wind and soil. Water and fire are the sufficient and required conditions for continuing life and striving. Both of them can be devastating while being life-giving. Besides the role of water in the fire-temples the Ilamese engineers had reached to advances in transferring water to the dry areas and also water refining processes.

Water in Islamic era architecture

In Islamic era the role of water finds an applied practical use in the architecture. The architectures of this period have consciously tried to dominate the nature and give it order. Before Islam the architecture hastily dashed towards water and settled down beside water streams. After Islam, the architectures brought water inside the buildings through realizing the physical laws of the water behavior and understanding its role, exemplification and relationship with the mankind. The water was organized into geometrical shapes and containments in the majority of the Islamic era buildings and it can be claimed that in that era the architectural centrality and unity are shaped in water. In this way, the water entered our buildings and construction to the extent that a clear separation cannot be imagined in practice between water and the constructed structure. In desert and dry regions in Iran, the scarce and life-bestowing water caused the creation of water reservoirs, caravansaries, shoals, fridges, springhouses and so forth. In the sections to come in the current study we deal with the survey of a special format of buildings which provides the residents with a pleasant environment in the hot summers and it is indicative of the Iranian architecture genius in establishing a peaceful relationship with the nature.

The effect of water presence in architecturing space

The artificial buildings and spaces cause the human beings to get away from the nature and that is because the humans have tried to somehow protect themselves from some of the natural factors and on the other hand to provide themselves with a more humane territory, such characteristics have caused the human beings to reside in a more alienate environment and take refuge inside an environment with more cold and artificial qualities. Therefore, the need for some sort of linkage between the architecture and nature is what has been deemed necessary and such a theme has been thought over and contemplated in the iranian architectural arts and garden-

making processes via the use of water which is considered somehow as being sacred, invaluable and rare. Such a use has been in a way that the link between architecture and the peripheral landscape has been made probable through this common feature and factor and the springhouse space which has been made for the same purpose is regarded as some sort of a buffering and semi-open space between the open and closed or the internal and external space



Fig:1. A sample of a fountain in Kashan's Fin Garden [5]

Changing the climate via water

The temperature and the special heat capacity of the water is higher in respect to the other masses on the earth. Due to the same reason the water has more capacity for storing heat in comparison to the average heat absorption capacity of the other masses on the planet earth. Generally speaking, the existence of the water resources causes equilibrium in the air temperature. As the existence of water in the regional climate can entice equilibrium between the night and day temperatures, inside the buildings it can also reduce the temperature fluctuations as the creator of a microclimate. On the other hand, the air heat capacity is very low and the air has a very low heat storing potential. But due to the presence of the water vapor particles, the moisturized air can better store the heat. Thus, in wet areas the difference between the day and night temperatures is lower than the regions with dry climate. Therefore, in microclimates passing the air over a moist surface causes the peripheral environment to cool down and through circulating and directing this cold air towards the rooms and the living rooms the comfort conditions can be provided. One architectural texture typology that has been created to make use of the element of water for cooling down the spaces in the warm and dry cities is springhouse.

Warm and dry climates

One of the pertinent and highlighted features in such climates is the warm and dry air in summer and cold and dry weather in winter, low precipitation level, very low air humidity, low vegetative cover, the high difference between the diurnal and nocturnal temperature and also as a result of being distant from the sea level the amount of the air humidity being very lower than the human comfort threshold. Also, the sun radiations and the heat in summer cause a scorching and warm ambient air to be formed. Thus, according to the fact that a vast area of Iran has been situated in the warm climate in the traditional architecture of this land spatial chilling and cooling are of great importance. The traditional architects have deployed numerous architectural solutions and elements to create temperature comfort and convenience. Among such elements we can point to the springhouses. So by devising a springhouse inside the residential spaces of such climates we can bring about an increase in the humidity in the biological spaces inside the buildings and placing and directing the entire opening and orifices towards the moisturized and temperate space of the springhouse has set the grounding for the creation of a microclimate which is thought to be appropriate and convenient for the human comfort in dry and warm climates

Spring house

Springhouse is a space for spending summers and it is usually made in an octagonal shape. In between such a space a small pond is made and it is usually made with eight angles therefore the reason for calling it an octagon and the existence of cold water inside the space causes the ambient air to become moisturize and cold and

subsequently reduces the temperature during the hot summer days. Springhouse is a closed and covered space and it takes its light from the rooftop and in some of the springhouses high and lofty windbreakers are built to get the cold air entered the interior space of the springhouse. The springhouse functional system is in this way that the water poured on the surface of the pond by a fountain and through the moving winds the cold air is circulated and causes the peripheral air to cool down.





Fig.:2. springhouse in Yazd's Dowlat Abad garden (source: www.parks.tehran.ir)

The role of water in the springhouse

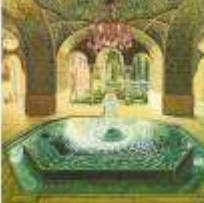
Table:.1. the role of water in springhouse (source: AlboGhabish et al, 2013: 6)

No.	Perspective	Explanations	Images
1	Symbolic aspect (water sacrosanctity)	The symbolic aspect of the water has been highlighted in springhouses through making the springhouse's roof higher than the adjacent spaces and placing the pond in the center of the building and the reflection of the highly versatile and elegant works in the water of the pond and enhancing the feeling of radiation	Figure.3. Mowstowfi House in Basharooeyeh 
2	The spiritual role (influencing the spiritual aspect)	The presence and the sound of the water cause a sort of tranquility in the human being	Figure.4. Golestan palace spring house (by Master Kamal Al Molk) 

3	Alignment with the nature	Drawing water into the buildings due to the close relationship between the human beings and the nature	<p>Figure.5. springhouse in Kashan's Ehsan House</p> 
4	The use of reflectivity feature	Sometimes water has been used as a mirror and doubles the house aesthetic manifestation	<p>Figure.6. Haj Agha Ali springhouse in Rafsanjan</p> 
5	Applied and functional presence (from climatic point of view)	The use of water for the purpose of its chilling effect through evaporative coolness	<p>Figure.7. Kashan's Fin Garden springhouse</p> 

The reasons behind building springhouses

In the past, the architecture were thoughtful of making spaces in which the people could have access to relatively comfortable places in the summers and its warm weather inside the cities, such spaces besides providing the people with the ability to tolerate the warmth enabled them to attend to their occupational affairs and prevented them from leaving the cities incumbently to escape the air high temperature and seek refuge and rusticate inside the more temperate summer-quarters or countries, therefore a new element was added to the homes which was specially invented and used for the summer and hot seasons and that was springhouse. Thus, the springhouses were capable of providing the home dwellers with a pleasant space in hot air conditions and they rapidly found popularity and as a result of their favorable characteristics and due to being easily and readily buildable they became widespread and the buildings were equipped with a device that could provide them with pleasant weather in the hot seasons of the year.

The general features of the springhouses

1. Two to four rooms were built in the periphery of the springhouses with wooden doors which were opened to the springhouses.
2. The rooms' floors were about one meter higher than the springhouse space.
3. The springhouse light was supplied through windows and sometimes the orifices inside the roof.
4. There were opening spaces which were exposed towards the front yards.

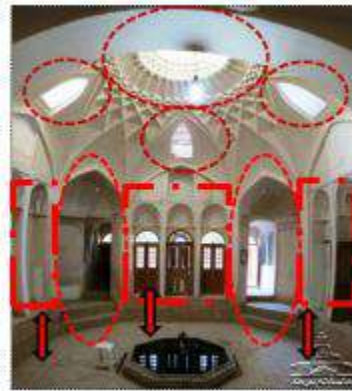

Fig..8. springhouse features (source: the author)

The use of favorable winds in the springhouse

In this regard, the study theme should be surveyed from two perspectives:

Firstly, the wind entering the house should be a summer-favorable wind and it should not be bringing dust, pollution and so on with it; furthermore, it should be considered from the perspective of the rate and the way it enters and the way it circulates into the inner spaces. The form and the pattern of the air movement inside a room is influenced by two factors of the quality of the air pressure around the building and the moving air inertia inside the whole building. When the window is designed to be placed inside the wall opening to the direction of the wind the pressure inside the room is increased to some extent to equalize with the air pressure in the exterior section of the window. If another window is also designed and used in the opposite to wind wall (the area under suction), the internal air pressure of this section is also decreased to the extent that it create equilibrium with the air pressure in the exterior part of the window. In both of the cases the average air pressure of the inside and outside stabilizes.

Table. 2. The favorable wind usability analysis in springhouse (Source: authors)

Subject	Explanations	Image
Figure.9. the wind-orientated springhouse openers (source authors)	The opening space towards the front yard should be oriented in the direction of the favorable winds. And this wind usually blows northwestern to south eastern	
Figure.10. the effect of the orientation and the type of the window opener (source: the authors)	The wind-oriented opener and the external window in the direction of the low pressure air causes the air moving in this space to pass over a surface of the water and the created cold air can be directed towards the rooms.	
Figure.11. window dimensions (source : the authors)	The smaller the dimensions of the window, the higher the speed of the wind, therefore it is better for the inter-room windows to be of smaller dimensions to act as a channel	

		Considering the constant volume of the air, movement of the wind through a smaller space causes the wind speed to increase
--	--	--

In fact, the springhouses are oriented towards the optimum and favorable winds in order for the wind to enter directly to the space and after circulating appropriately and passing over the water it can be transferred to the peripheral rooms through windows which have been designed in proper places and with proper dimensions and sizes.

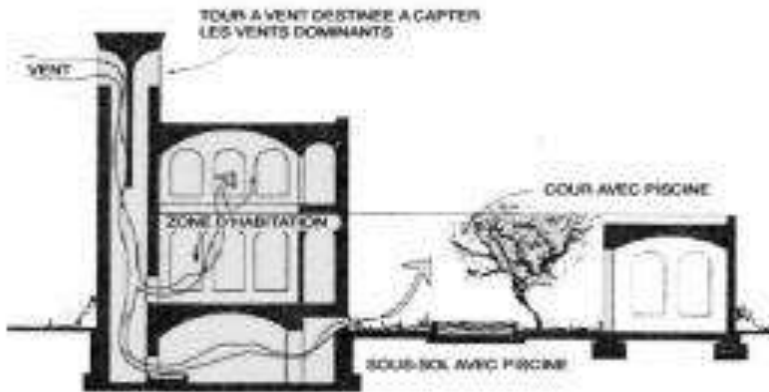

Fig: 12. The movement direction orientation of the favorable winds (source: www. Details dararchitecture.com)

Introducing the analytical sample

The city of Shiraz

The city of Shiraz is located along the longitude of 30° and 02' and latitude of 27° and 32 ', in a region with 1071 meters elevation from the free sea level in a dry and warm climate [8]



Fig: 13. Shiraz's latitude and longitude coordinates (source: authors)

Generally, in order to reach to a comfort condition in every region there is a need to establish a proportion between the temperature and the humidity. The wind speed is also effective in creating such a condition. Since the city of Shiraz is in the warm and dry climatic conditions and because it has dry summers, through the use of direct cooling and evaporation we can approximate the air temperature to comfort conditions. One of the very widely used methods for the purpose of evaporative cooling of the space is the use of springhouse inside the buildings.

Forrogh Al-Malek house location

One of the historical neighborhoods in the city of Shiraz is the black stone (Sang-e-Siah) locality. In this neighborhood among the Qajarieh traditional houses three homes have springhouses and in this project Forrogh Al-Malek House was selected among the three houses because of being qualified for getting a clear understanding of the building and its appropriate conditions for the purpose of analysis and measurement of the temperature and humidity.

Forrogh Al-Malek House

Forrogh Al-Malek House belongs to the late Qajarieh era and it is located in one of the old textures of the city in Sang-e-Siah neighborhood, behind the holy shrine of Imamzadeh Bi Bi Dokhtaran. The building was constructed in 1931 by Forrogh Al-Malek Ghavami on a 1020 square meter area. The building was built in three levels of basement, ground floor and the first floor for residential uses and it has two exterior and interior sections with two separate yards, alcove, springhouse, bathroom, kitchen parts, etc. the exterior section of the building was used by the family members for living and the interior section was used by the servants. One of the most splendid sections of the building is the very spectacular springhouse which is placed along the northwestern diagonal of the building, the springhouse has been built based on an octagonal plan and also there is an octagonal pond in the middle. The springhouse has an alcove with two pillars which connects the exterior section to the interior one.



Fig.:14. Forrogh Al-Malek House in Shiraz (source: author)

The location of the springhouse in Forrogh Al-Malek House in Shiraz

Table: 3. the location of the springhouse, adjacency and access

The springhouse position		Springhouse adjacency		Access to the yard	
The building's western frontier		It has a three-direction access to the room		It has three opener directed towards the yard, one opener towards the exterior yard and another one towards the interior yard	



The masonry applied in building Forough Al-Malek springhouse

Table:4. The built body

The masonry used in the body	Walls colors	Windows and doors material	Springhouse's floor alignment to the yard/ cm	The ratio of the adjacent rooms' springhouse area	The masonry used in the floor
Brick + stone	Light cream	Wood	+60	1.4	Stone

The roof shape and the springhouse's geometrical shape in Forough Al-Malek House

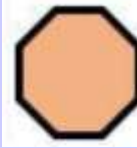
Table: 5. the type of the roof used and the springhouse shape

Springhouse image	Roof type	Windbreaker	Springhouse shape	Pond shape
	Dome-like	No windbreaker		Octagonal 

The direction of the wind movement in Forough Al-Malek Home Springh

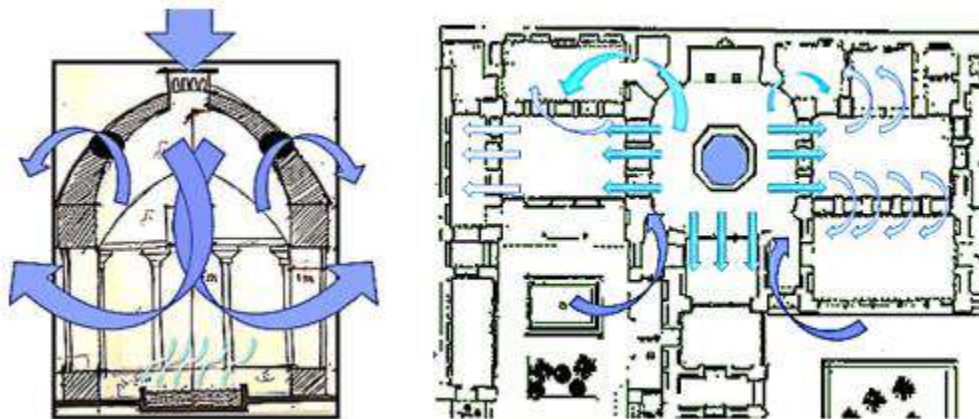

Fig:15. The wind direction and humidity orientation in Shiraz's Forough Al-Malek Home (Source: the author)

MATERIALS AND METHODS

The study methodology was in this way that the data measurement was conducted in two days with an identical temperature and humidity three times every day. In such a way that firstly on the first day the temperature and the humidity were measured with the empty pond (three times in the morning, noon and afternoon) and then on the second day the temperature and the humidity were measured with a full pond in those three times of the day and in various points in the springhouse space. The temperature and humidity data measurement method was through taking advantage of the data logger device. The device application methodology should be in a manner that it should be placed in a 5.1-meter height from the ground level and without making hand contact the temperature and the humidity of the environment should be measured in the points indicated on the plan.



Fig:16. The full and empty pond images in Forough Al-Malek Home’s Springhouse

The point selection order for measuring the temperature and humidity in springhouse and the peripheral spaces on Forough Al-Malek home plan

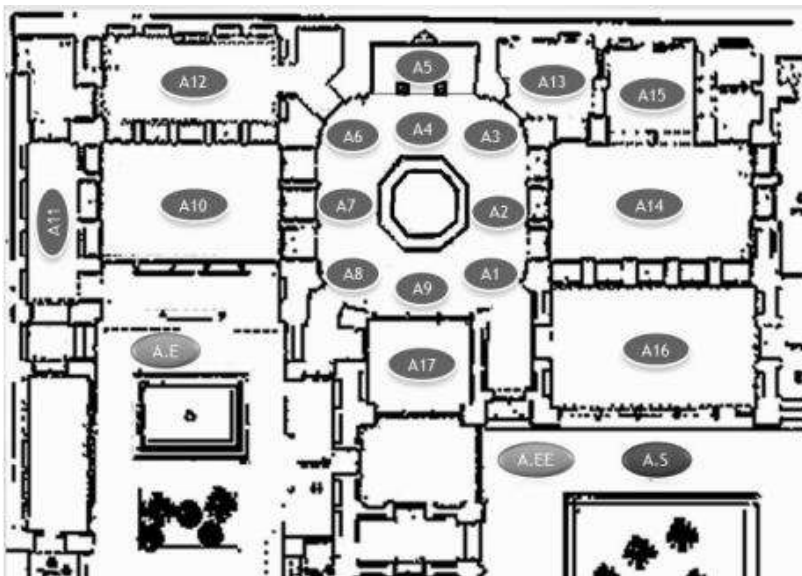

Fig:17. The point selection order on Forough Al-Malek home plan (source: the author)

1. Temperature analysis in various points in the springhouse
 - a) Morning time analysis

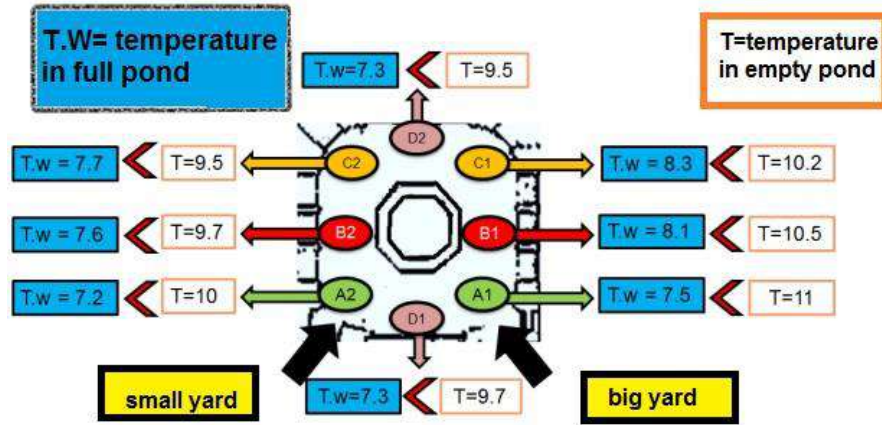

Fig.:18. The inter-springhouse points' temperature rate with full and empty pond (source: the author)

b) Noon-time analysis

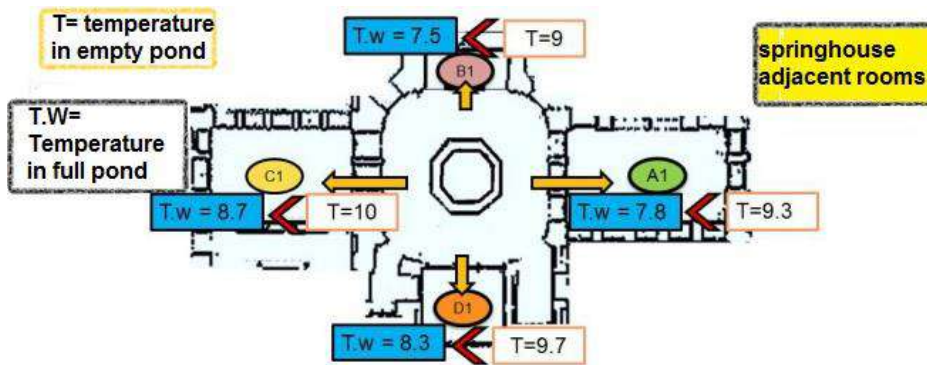

Fig: 19. the temperature rate in the adjacent rooms to the springhouse with empty and full pond (source: the author)

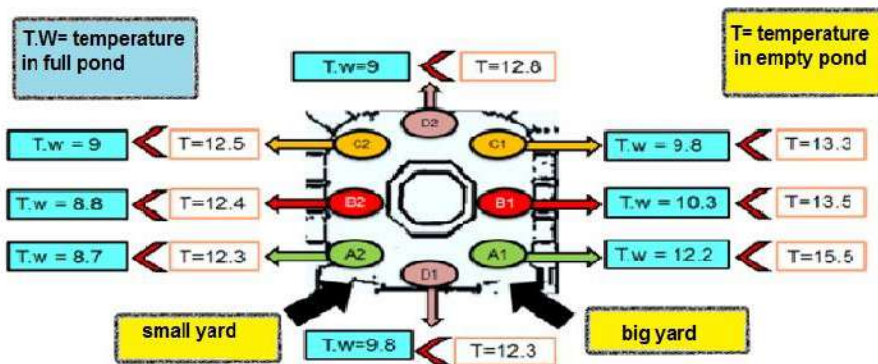

Fig:20. The temperature rate in points inside the springhouse with empty and full ponds (source: author)

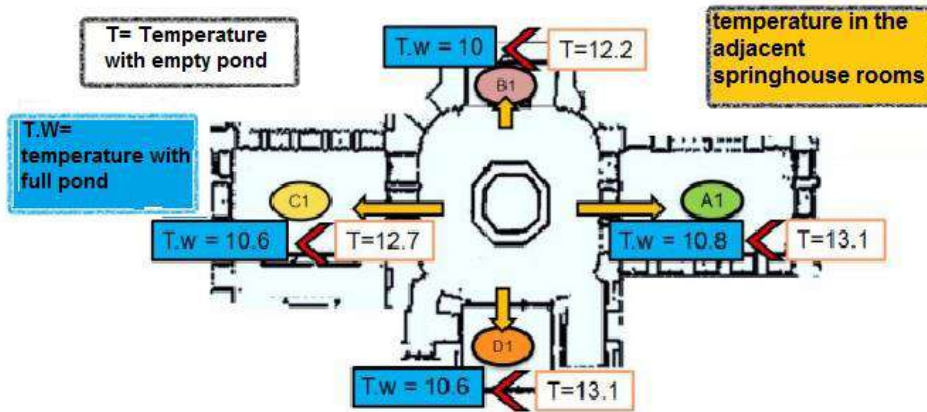

Fig: 21. the temperature rate in the springhouse adjacent rooms various points with empty and full pond (source: the author)

c) Afternoon time analysis:

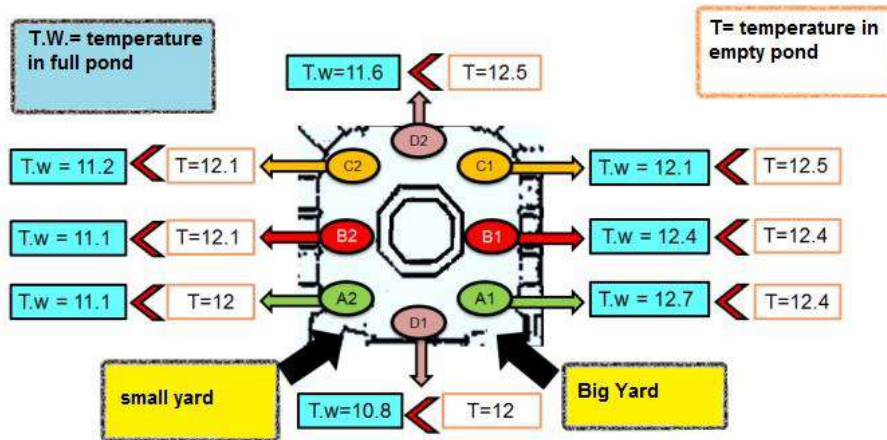

Fig:22. the temperature rates in springhouse various points with full and empty pond (source: the author)

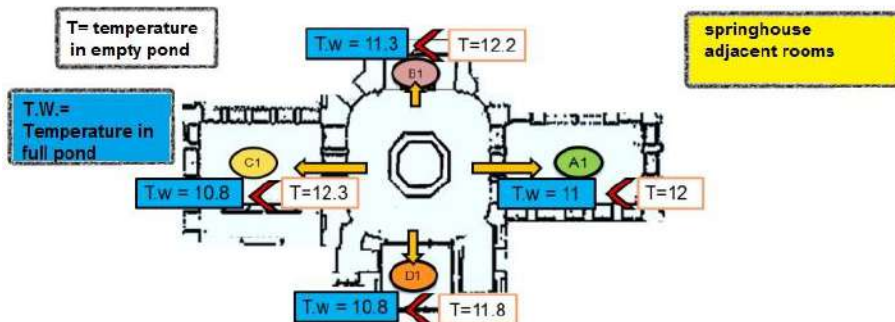

Fig: 23. The temperature rates in various points in springhouse adjacent rooms with empty and full pond (source: the author)

The humidity analysis in various points in the springhouse

a) Morning time analysis

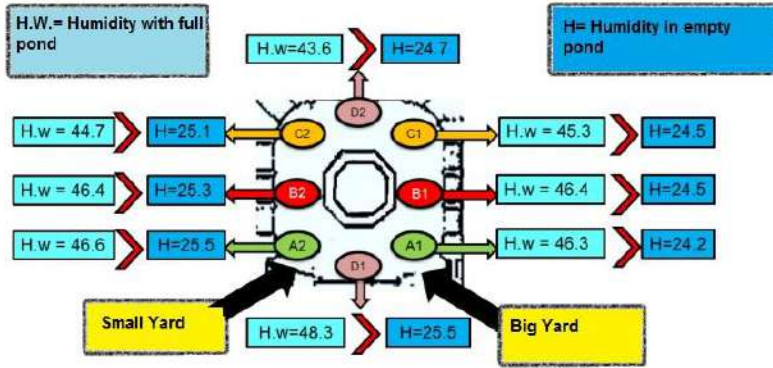

Fig:24. the humidity rate in various points in the springhouse with empty and full ponds (source: the author)

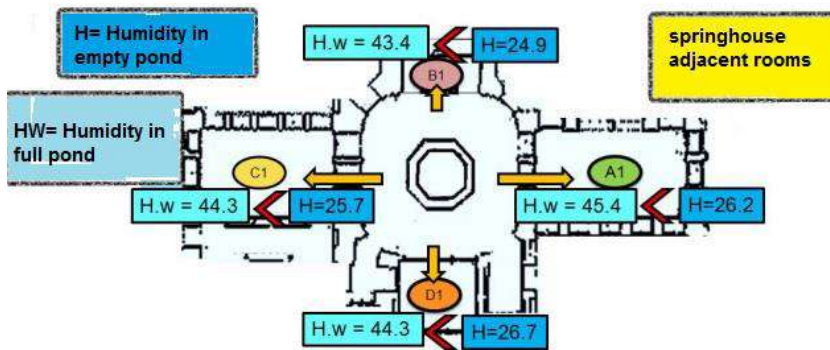

Fig: 25. The humidity rate in various points in the springhouse adjacent rooms with empty and full ponds (source: the author)

b) Noon time analysis

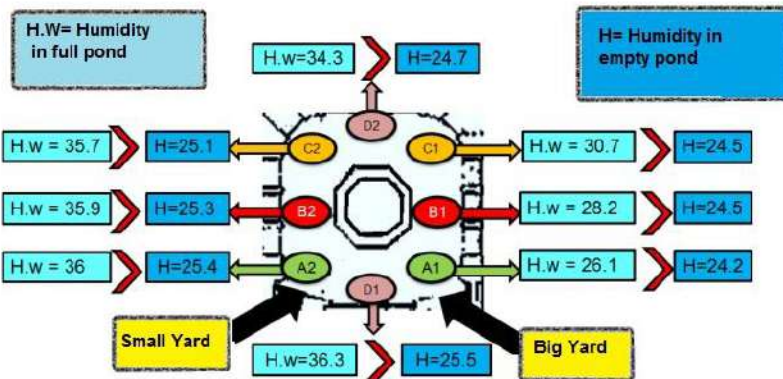

Fig: 26. The humidity rate in various points inside the springhouse with empty and full pond (source: the author)

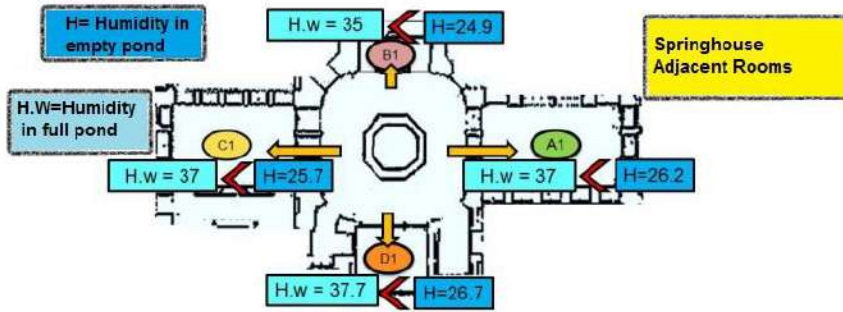

Fig: 27. The humidity rate in various points in the adjacent rooms with empty and full pond (Source: the author)

c) Afternoon time analysis

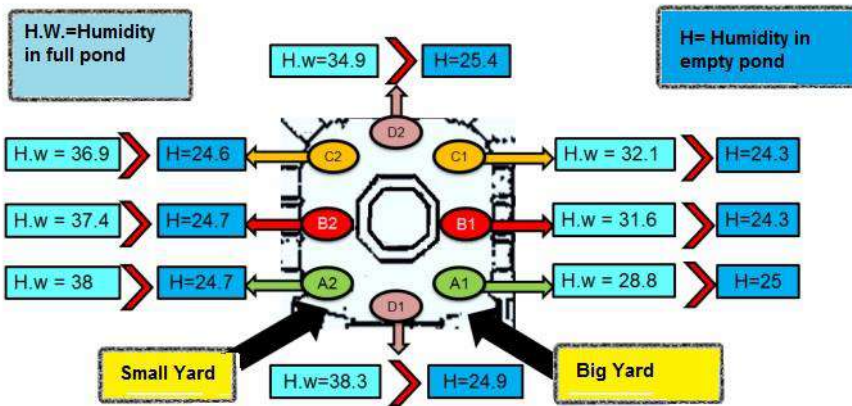

Fig:28. Humidity rate in various points inside the springhouse with empty and full pond (source: the author).

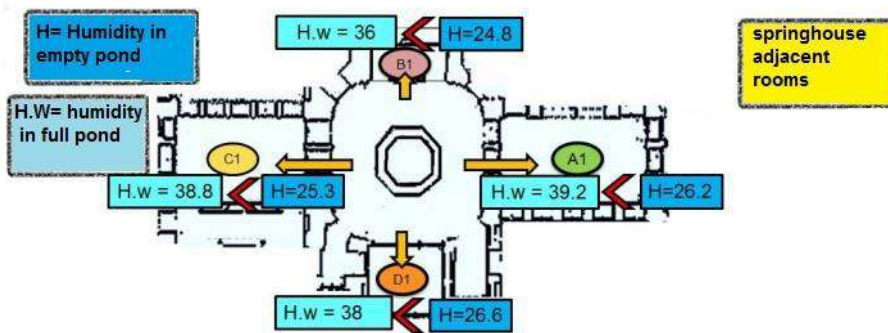

Fig:29. The humidity rate in various points in the adjacent rooms to the springhouse with empty and full pond (source: the author)

CONCLUSION

a) Analytical and comparative temperature rates conclusions

The results obtained from the temperature diagrams in three morning, noon and afternoon times are explained as below:

In morning time

1. The temperature in the entire points in the springhouse is lower with the full pond than the time it is empty.
2. The points A1 and A2 are located beside the door opening to the yard and their temperatures, with empty pond, is more than the temperature in the points opposite to these two points due to being exposed to the sun. Also, when the pond is full, though all of the temperatures witness a decline but due to the presence of a direct blowing by the wind in these points the temperatures become less than their opposite points.
3. Points A1, B1, C1 due to being along the door opening to the yard and because of being exposed to the sun for a longer period of time in the big yard in contrast to the small yard their temperatures are usually more than the temperatures obtained for the points A2, B2, C2 both with full and empty ponds and the latter points are located along the small yard which is conversely exposed to more shade.
4. Because the adjacent spaces are 1-meter higher than the springhouse and the hot air moves upward the temperature for this section is more than the temperature for the springhouse both with empty and full pond.
5. The spaces which are exposed to direct sun such as D1, C1 are found to have a higher temperature rate both in empty and full pond.

At noon time

1. At noon time, also the temperature in the entire points in the springhouse and the adjacent rooms are less than the temperatures with full pond in contrast to the empty pond.
2. The longer the points get away from the entrance to the big yard and move towards the small yard their temperatures decrease both with empty and full ponds.
3. Room A1 has been connected to five doors leading to the room which opens to the big yard and the room C1 is adjacent to the small yard and at noon times the big yard is exposed to the direct sunlight but the small yard has an indirect sunlight and due to the same reason the temperature in A1 is higher than C1.

In the afternoons:

1. In the afternoons also the temperatures for the entire points in the springhouse have been found to be lower with full pond in respect to the empty pond.
2. In the afternoon due to the existence of more shade and the lessening of the sun light intensity outside the temperature inside the springhouse has been shown to indicate smaller variations and differences with empty and full ponds.

Final conclusion regarding temperature in three times, (morning, noon and afternoon)

1. Generally speaking, the temperature is lower in the entire points and during the entire hours of the day than the temperature with empty pond.
2. The closer we get to the noon the springhouse temperature both with full pond and empty pond gets higher than the morning and evening temperatures.
3. The spaces exposed to the direct sunlight have higher temperatures both with empty and full pond.
4. The points in the vicinity of the big yard have higher temperatures in respect to the points besides the small yard.

The humidity analysis and comparison results

The results obtained from the analysis of the humidity diagrams during three morning, noon and evening times are as follows:

In the morning:

1. The humidity in the entire points in the springhouse and the adjacent rooms with full pond is more than the humidity with empty pond.
2. During the morning time with empty pond, the humidity rate in points A1, B1 and C1 is lower than the

humidity in the points A2, B2 and C2 which are in a closer distance from the small yard enjoying more shade in respect to the big yard which has to suffer more of the sun light.

3. In the morning time, due to the reason that the sunlight has not reached to its full scale the air humidity is higher with full pond in points which are located in closer distance from the entrance doors to the yard as a result of being cooler but in the points which are in a far distance from the entrances and are therefore relatively warmer the humidity is lower.

At noon

1. At noon times, the humidity is higher with the full pond in the entire springhouse points in comparison to the empty pond.

2. At noon time with the full pond, the humidity rate in the points A1, B1 and C1 due to the higher rate of the sunlight in these points is more approaching to the humidity value when the pond is empty but the humidity rate in the points A2, B2 and C2 which are closer to the yard is higher with full pond in comparison with the empty pond.

3. The humidity in the entire adjacent rooms to the springhouse is higher with full pond than the humidity with empty pond.

4. The humidity rates in the springhouse adjacent rooms at noon and in the morning when the pond is empty are identical but with the full pond the humidity rate gets to a higher level at noon times.

In the afternoon

1. In the afternoon time the humidity rate in the entire points in the springhouse and in the adjacent rooms is higher with the full pond than the humidity with the empty pond.

2. In the afternoon times also the humidity rate is lower in the points closer to the big yard than the humidity rate in the points closer to the small yard.

3. The humidity in the adjacent rooms is higher in the afternoon in contrast to the humidity rate at noon.

Final results of the humidity analysis in three times, (morning, noon and evening) :

1. The humidity rate with the empty pond does not show much variations during the various hours (morning, noon, afternoon) but with full pond the humidity is higher in all of the points during the entire hours of the day and night.

2. The presence of openers or orifices to the yard which assists to the air movement is of an influence on the humidity rate.

3. In every point the humidity rate is higher with full pond during the mornings and at noon the humidity is reduced as a result of the increase in the temperature and in the afternoon the humidity again reaches elevated levels due to the decrease in the temperature. So, the temperature variations are effective on the humidity.

4. The humidity in the entire adjacent rooms to the springhouse are more with full pond than the humidity with empty pond.

Final results regarding the analysis and comparison of the temperature and humidity in the entire points:

Generally, when the pond is full of water the temperature goes down and the humidity is increased. So, it can be concluded that in the dry and warm regions the favorable and pleasant weather can be achieved through only using a pond full of water and without needing to make use of the other energy forms.

CONFLICT OF INTEREST

Authors declare no conflict of interest.

ACKNOWLEDGEMENTS

None.

FINANCIAL DISCLOSURE

None declared.

REFERENCES

- [1] Alboghabish Mokassari, Mona et al, [2013]springhouse (case study: Shiraz's traditional homes in Sang-e-Siah neighborhood), civil engineering international conference", architecture and sustainable urban development
- [2] Aminia S.[2006]Kashan Springhouses", the collection of the articles from the second Iranian architecture and urbanization history congress, v.2, Cultural Heritage organization, Tehran
- [3]Abbas Zadeh Sh. [2002] water and mirror", the specialized international journal of the cultural heritage and tourism, 5(32-33).
- [4] 'Alam Al-Hoda, Hoda, 2002, "water in Iranian architecture", art moon book, May and June, 2003, pp.84-90
- [5] Alishahi, Mona. [2010]the standpoint of the water in Iranian-Islamic urbanization and architecture, contemporary Iranian architecture and urbanization national meeting
- [6] Fatehi, Muhamma Ali and Faz Allahi, Ali.[2006] Kavir architecture regional and scientific meeting
- [7] Ghobadyan, Vahid. [2014]the climatic survey of the Iranian traditional buildings, 2nd ed, Tehran University
- [8] Kasma'ee, Morteza. [2011] climate and architecture, 4th ed., Khak Publication, Tehran
- [9] Mahdizadeh, Seraj, F.,[2008] the optimum and effective use of the clean energies the only solution to the environment preservation, petroleum, energy and environment national meeting, Tehran
- [10] www.parks.tehran.ir
- [11] www.detailsdarchitecture.com

**DISCLAIMER: This article is published as it is provided by author and approved by reviewer(s). Plagiarisms and references are not checked by IIOABJ.